



The Classic

As the name suggests, this timeless model exudes a clean shape and attractive finish. It's unique patented design engages customers with its angled screen and offers ease of accessibility. The Classic's modular design boasts easy maintenance and operation with easy rear access.

AVAILABLE COMPONENTS

- Credit Card Payment Terminal
- Barcode Scanner
- Rugged Keyboard & Trackball
- WiFi or Cellular Connectivity
- HD Camera

Available Screen Sizes



17"

19"

22"

26"

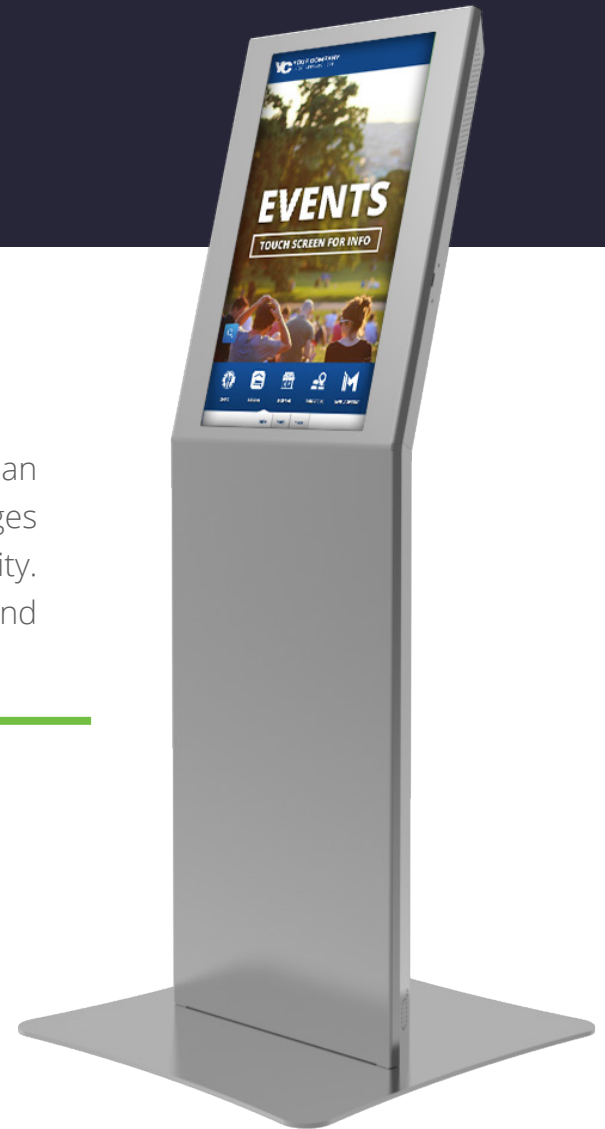

SCREEN

- Screen sizes range from 17-26 Inches
- High Definition LED
- 1920x1080P Resolution**

**On most screen sizes and models. Request specifications for specific screen sizes.

STANDARD COMPONENTS

- Durable 14 Gauge Steel Enclosure
- PC - Solid State Drive, i3, i5 ,or i7
- High Quality Powder Coat Finish
- Standard Security Locks
- Front Access
- ADA Compliant

POWDER COAT OPTIONS

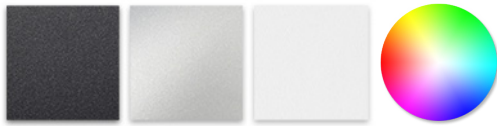

STANDARD INDOOR

Black, Silver, White

STANDARD OUTDOOR

Black, Grey, Grey Metallic, Hammered White



DIMENSIONS (26" UNIT*)

Height: 57.75"

Width: 17.65"

Depth: 4"

Base Plate: 24.3" x 24.3"

Weight: ~170 lbs

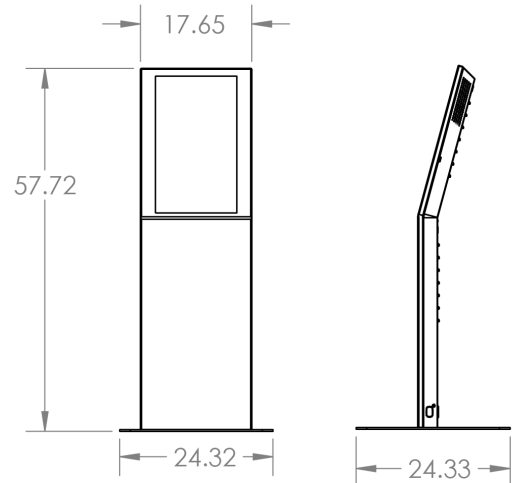

**Dimensions and drawings for other screen sizes available upon request*

POWER

- 120 Volt, 20 AMP Circuit, 50/60 Hz
- Internal Power Strip with Surge Protection
- International Power Conversion Available

CUSTOM PANTONE MATCHING AVAILABLE

For More Information

SALES@MZERO.COM | 866 454 6757

A complete end-to-end self-service innovator, Meridian's turn-key solutions are designed and manufactured from our headquarters in North Carolina. By building all of our products from start to finish, we're able to provide greater efficiency and leaner, high-quality products faster than anyone else in the industry.



QUALITY + CERTIFICATION

Meridian promises a level of quality that goes beyond the expected. We control every step of our process from concept to completion, overseeing quality, design, cost and timelines. Many of our products can be UL Listed through UL self-certify and our processes are ISO 9001:2015 certified.

